

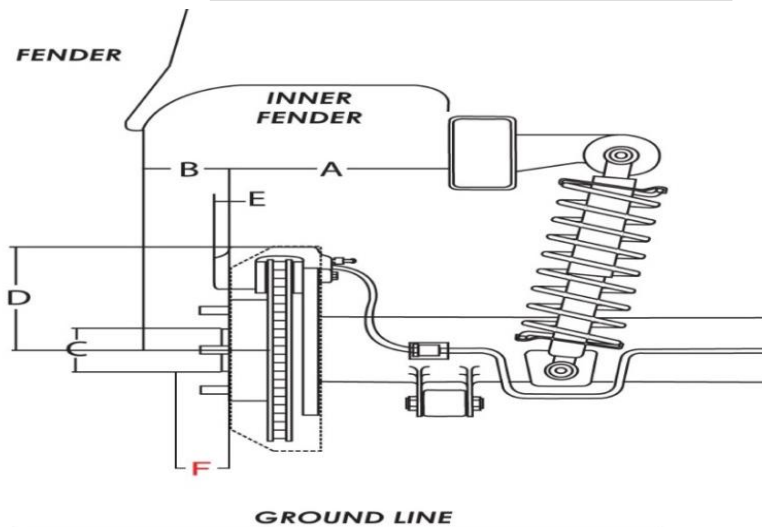

1277 Pacific Oaks Place, Suite 101 Escondido, CA 92029  
 Phone: (760) 737-0046 | Fax: (760) 737-0075

Customer: \_\_\_\_\_ Invoice # \_\_\_\_\_ Wheel Style: \_\_\_\_\_

**REAR WHEEL SECTION**



- Measuring Tips:**
- ✓ Jack vehicle up on level ground and support vehicle with jack stands
  - ✓ Compress suspension to ride height while measuring
  - ✓ Use a rigid straight edge at least 30" long for best results

	Driver side	Passenger side
A. Mounting surface to first obstruction frame side*	_____ in.	_____ in.
B. Mounting surface to inside fender	_____ in.	_____ in.
C. Hub diameter	_____ in.	_____ in.
D. Center to top of caliper	_____ in.	_____ in.
E. Protrusion of caliper past mounting surface (This measurement does not apply to vehicles with drum brakes)	_____ in.	_____ in.
F. Hub length	_____ in.	_____ in.
X. Inside caliper diameter	_____ in.	_____ in.

***I understand that the wheels are custom and will be made using the measurements provided. EVOD Industries will not be responsible for any fitment issues due to incorrect measurements.***

\_\_\_\_\_  
 Please print – First Name, Last Name                      Authorization Signature                      Date